



---

# STAYS & RESTRICTORS

# FS SERIES | ALUMINIUM FRICTION STAY

The Doric FS Series friction stay has been designed to suit most residential awning applications on aluminium, timber and uPVC windows.

## ADVANTAGES

- Extruded aluminium profiles
- Spin riveted connection on all joints
- Factory set friction to eliminate adjustment on site
- Geometrically accurate to ensure smooth positive operation
- Powder coated to increase protection from corrosion



<b>MATERIAL</b>	Aluminium
<b>FINISH</b>	Black

CODE	SIZE	STACK HEIGHT (±1mm)	MAX. SASH HEIGHT (mm)	MAX. SASH WEIGHTS (kg)	OPENING
FS0001	236 mm	13 mm	750 mm	6 kg	45 deg
FS0002	330 mm	13 mm	1000 mm	9 kg	35 deg
FS0003	515 mm	13 mm	1300 mm	12 kg	27 deg
FS0004	440 mm	13 mm	1200 mm	43 kg	20 deg
FS0005	730 mm	13 mm	1600 mm	60 kg	17 deg
FS0006	312 mm	13 mm	1000 mm	9 kg	55 deg
FS0010	245 mm	18.65 mm	750 mm	6 kg	40 deg
FS0011	330 mm	18.65 mm	1000 mm	9 kg	38 deg
FS0012	430 mm	18.65 mm	1200 mm	12 kg	28 deg
FS0124	430 mm	18.65 mm	1200 mm	12 kg	28 deg



# FS SERIES | ALUMINIUM FRICTION STAY

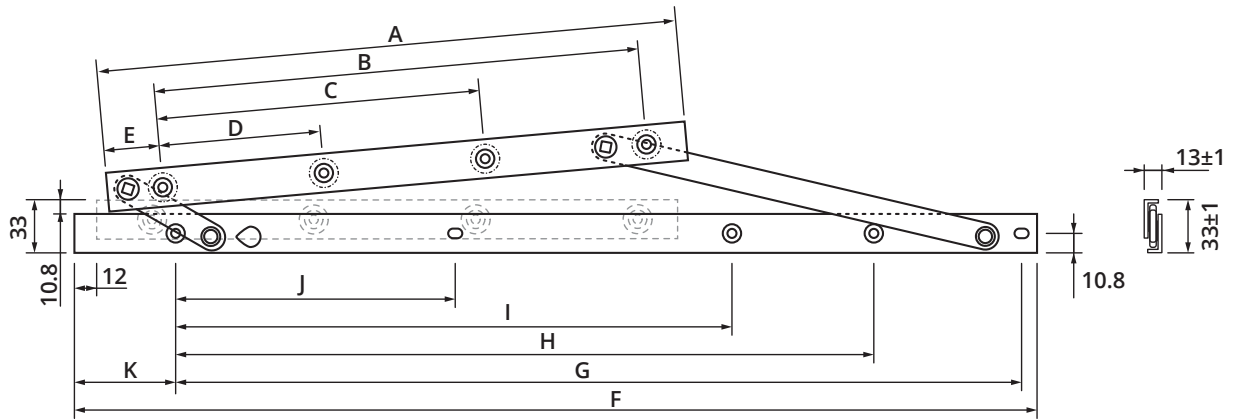

CODE	A	B	C	D	E	F	G	H	I	J	K
FS0001	110	65	29	-	30	235	172	-	-	55.5	54
FS0002	198	158	79	-	30	330	266	-	133	65	54
FS0003	310	258	172	86	30	512	450	-	296	148	54
FS0004	228	212	160	52	8	440	390	-	240	90	40

**FS0001** | ALUMINIUM FRICTION STAY  
- 236 mm PAIR



**FS0002** | ALUMINIUM FRICTION STAY  
- 330 mm PAIR



**FS0003** | ALUMINIUM FRICTION STAY  
- 515 mm PAIR



**FS0004** | HEAVY DUTY ALUMINIUM FRICTION STAY  
- 440 mm PAIR



**The only Aluminum 5 bar stay with triple arm support for greater performance on awning windows.**



The Doric FS0005 Heavy Duty Stay has been designed to suit most residential awning applications on aluminium, timber and uPVC windows.

The "Design Registered" Heavy Duty Stay provides the highest level of performance on heavier windows.

**ADVANTAGES**

- Fits all new residential suites in New Zealand
- Cycle tested to New Zealand Standards
- Extruded aluminium profiles
- Spin riveted connection on all joints
- Time saving and hassle free factory set friction eliminates on site adjustments
- Geometrically accurate to ensure smooth positive operation
- Registered NZ Design App No.: 427378
- Black powder coated to increase protection from corrosion

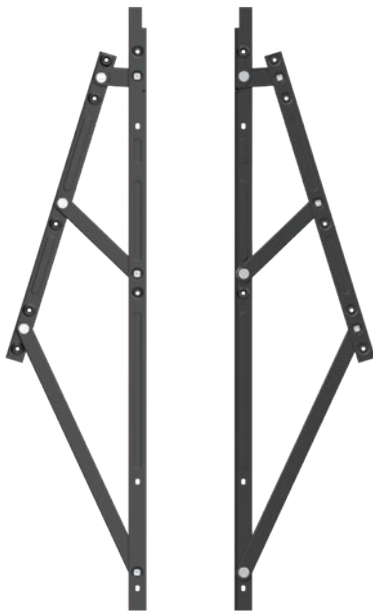

**PRODUCT DETAILS**

<b>WEIGHT CAPACITY</b>	60 kg
<b>LENGTH</b>	730 mm
<b>STACK HEIGHT</b>	13 mm
<b>OPENING ANGLE</b>	17 degrees
<b>ORDER CODE</b>	FS0005

**DIMENSIONS**

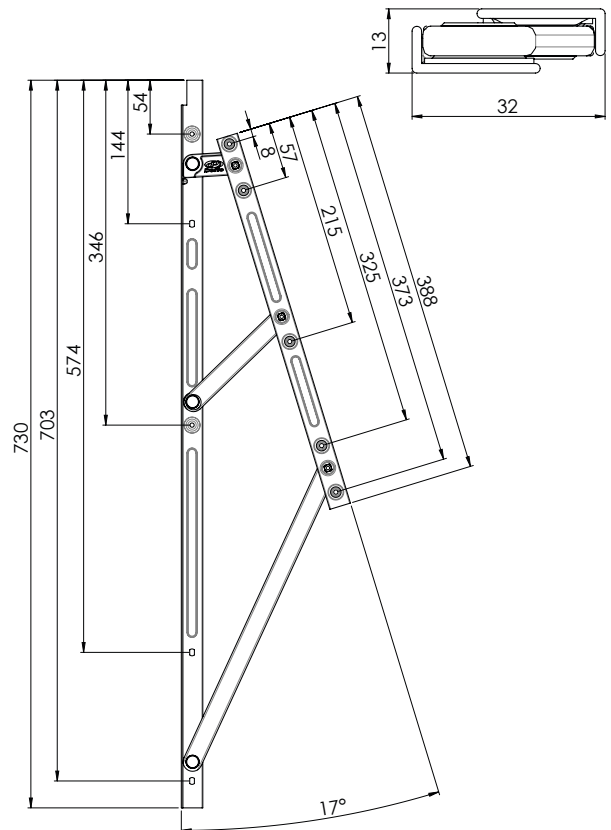

The FS0006 Casement Stay has been designed to suit small to medium size aluminium casement windows in residential applications.

## ADVANTAGES

- Suits small to medium size windows
- Fits residential aluminium casement windows
- Incorporated nylon ride up block

## PRODUCT DETAILS

<b>WEIGHT CAPACITY</b>	9 kg
<b>LENGTH</b>	312 mm
<b>STACK HEIGHT</b>	13 mm
<b>OPENING ANGLE</b>	55 degrees
<b>ORDER CODE</b>	FS0006



## DIMENSIONS

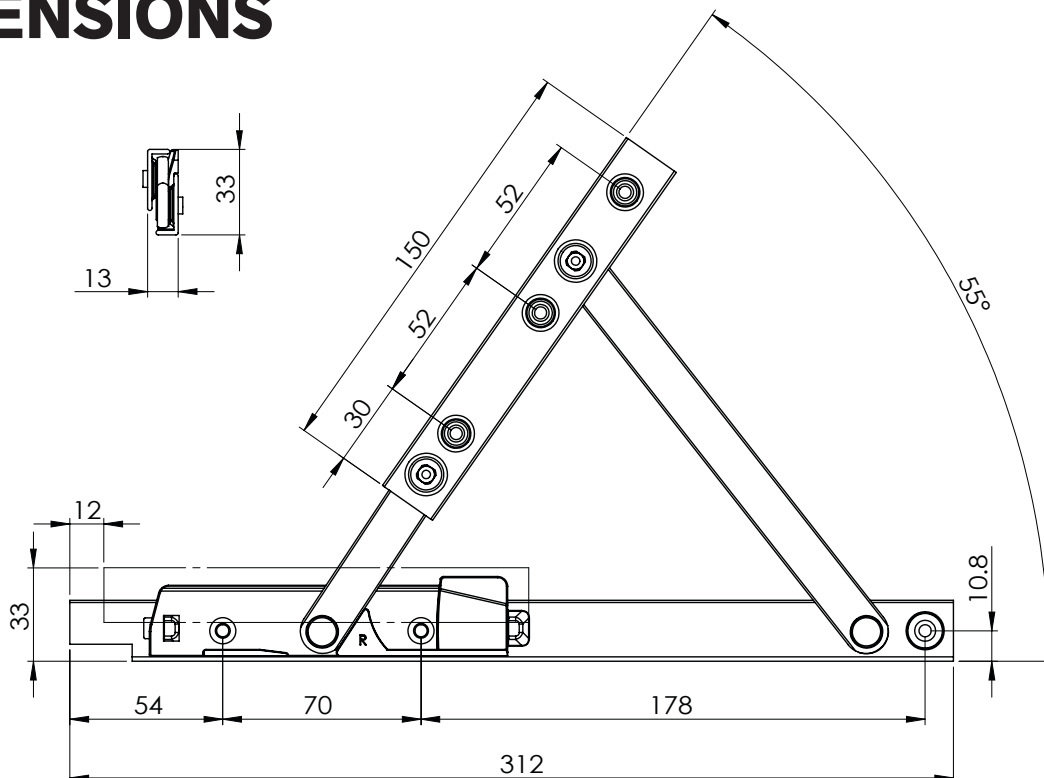

# FS SERIES | H-STAY ALUMINIUM FRICTION STAY

**FS0010** | H-STAY 245 mm (SMALL)

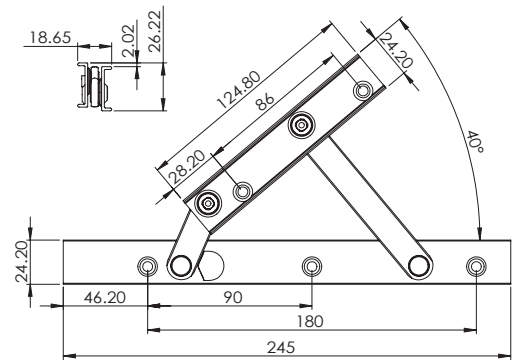

**FS0011** | H-STAY 330 mm (MEDIUM)

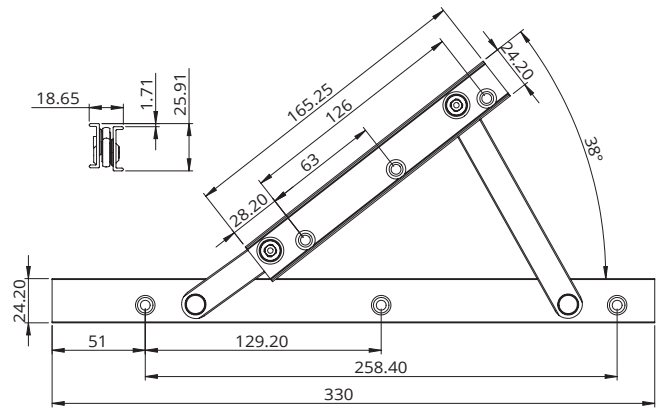

**FS0012** | H-STAY 430 mm (LARGE)

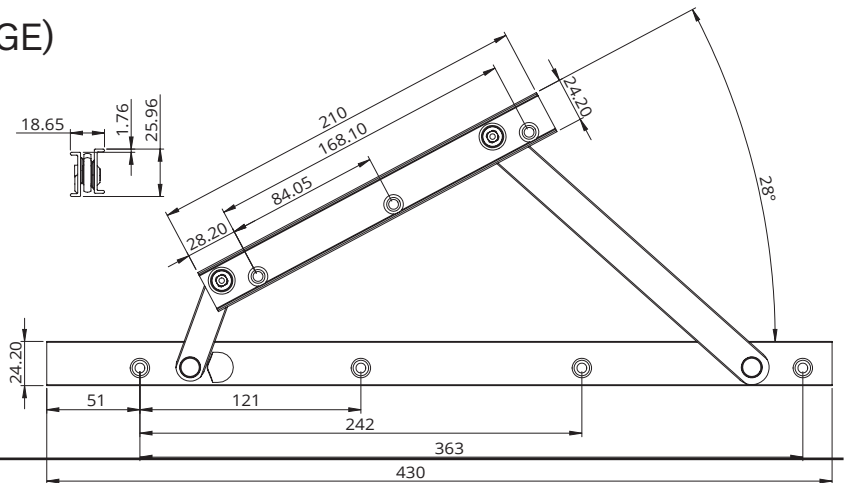
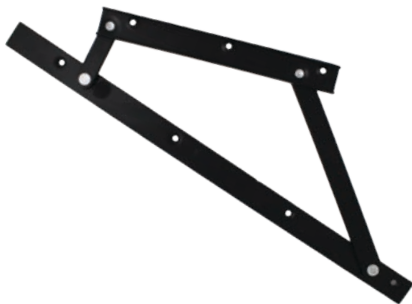

**FS0124** | ALUMINIUM HYBRID STAY 430 mm (PAIR)

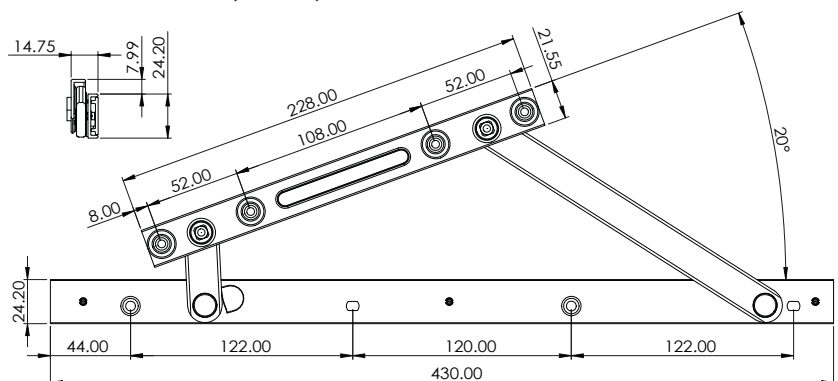

# SECURITY & RESTRICTORS STAYS | SECURITY STAYS

The Doric Security and Restrictor stays has been designed to suit residential and commercial awning applications. It is manufactured out of 304 Stainless steel for the excellent operational lifespan.

## ADVANTAGES

- Awning & casement windows
- Aluminium, timber and UPVC window frame
- Easy to install, non-handed
- Smooth operation & easy to clean



### SS0001 | SECURITY STAY

<b>MATERIAL</b>	304 Stainless steel
<b>SUITS</b>	Residential & Commercial

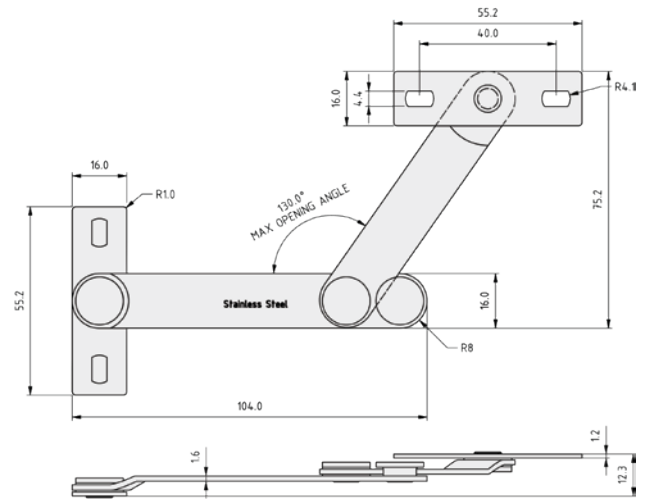

### SS0003 | KEY RELEASE RESTRICTOR STAY

<b>MATERIAL</b>	304 Stainless steel
<b>SUITS</b>	Residential & Commercial

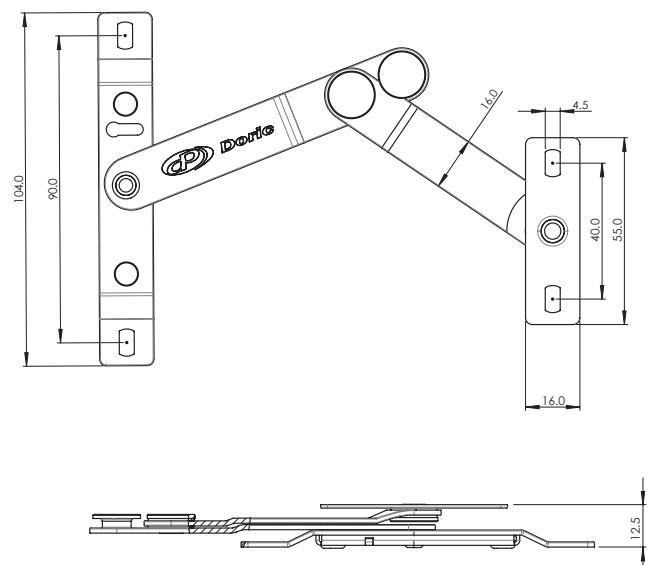
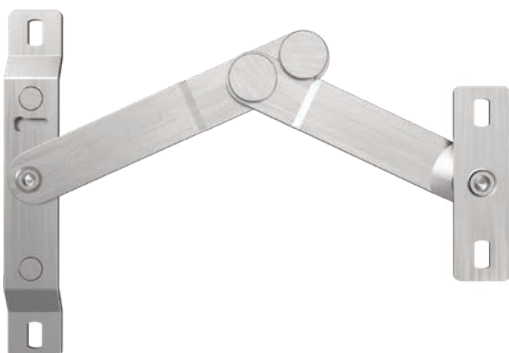

# INNOVATORS

OF HARDWARE FOR WINDOWS AND DOORS

---

DNZ STAYS & RESTRICTORS v1.2-20.09.2025

## **SYDNEY**

38 Redfern St,  
Wetherill Park  
Sydney, NSW 2164  
Australia  
Ph: +61 2 9609 2555  
[www.doric.com.au](http://www.doric.com.au)

## **AUCKLAND**

26/C Triton Drive,  
Albany, North Shore,  
Auckland 0632  
New Zealand  
Ph: +64 9 415 5535  
[www.doric.co.nz](http://www.doric.co.nz)

## **KUALA LUMPUR**

Unit 6, Level 4, SetiaWalk Mall (*Block K*),  
SetiaWalk, Persiaran Wawasan,  
Pusat Bandar Puchong,  
47160 Puchong, Selangor, Malaysia  
Ph: +603 8602 2100  
[www.doric.com.my](http://www.doric.com.my)



---

# STAYS & RESTRICTORS