



RESIDENTIAL SLIDING WINDOW LOCK

DN551
MORTICE LOCK



DN551 MORTICE LOCK

RESIDENTIAL SLIDING WINDOW LOCK

OVERVIEW

Designed for windows with box section profiles that demand a sleek quality finish in both residential (high density) or architectural living environments.

The DN551 is a sleek low profile accessory for sliding windows that incorporates an intuitive push and slide type mechanism and concealed finger recess.

Featuring flush aesthetics and modern styling the DN551 is the perfect compliment for window applications that demand style.

FEATURES

- Flush mounted
- Concealed fixing
- Self latching
- Adjustable latch tongue
- Durable Powdercoat finish

TESTING

- Has been tested for demanding New Zealand conditions including;
- Tested to 30,000 cycles
- 1000 hour neutral salt spray test.

TECHNICAL SPECIFICATIONS

Furniture Material:	Polesium
Finish Available:	Power Coat White, Black, Silver More Available on Request
Suitability:	Sliding Windows



DN551 with latch tongue

INSTALLATION AND ADJUSTMENT

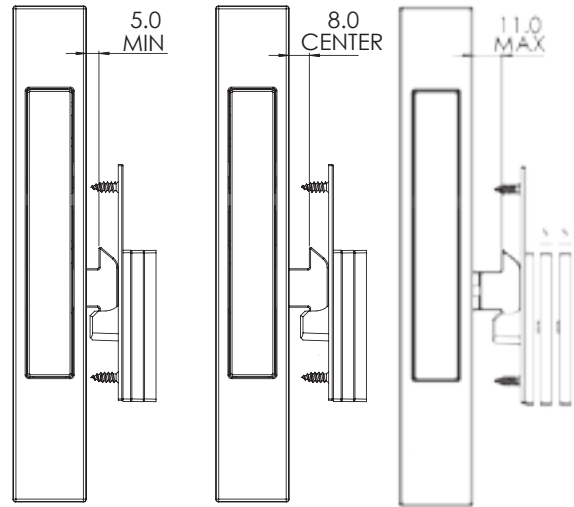
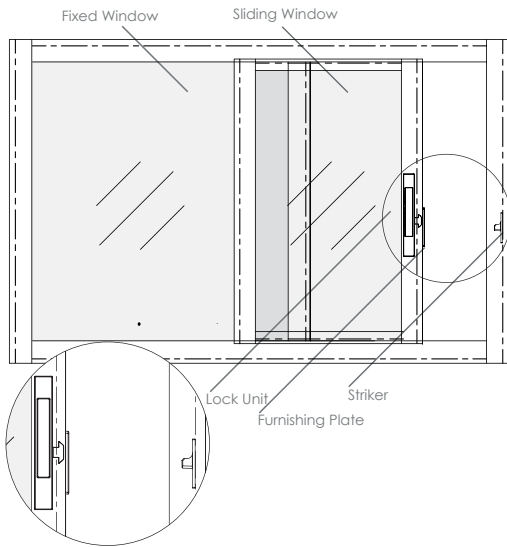

6mm horizontal adjustment can be adjusted after installation
2 x 5mm packers provided (Installation Optional)

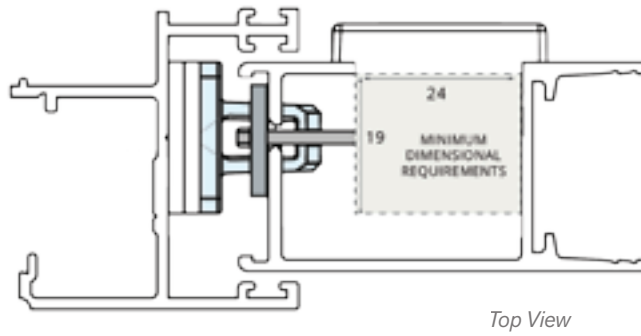

For further instruction on how to install and adjust the lock please download the DN551 fitting instructions from the Doric website.

Machining Detail

Sliding Stile

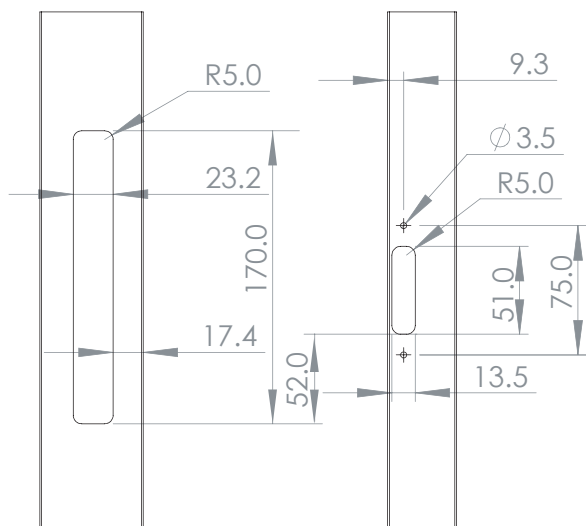

Meeting Stile

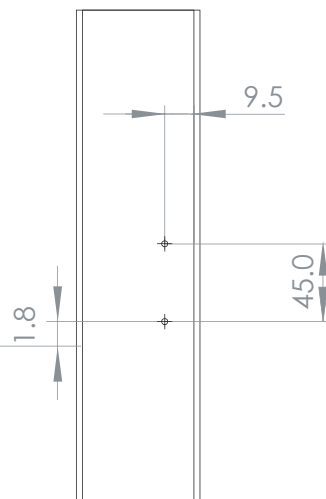



AUCKLAND
26/C Triton Drive,
Albany, North Shore,
New Zealand 0632
Auckland
Ph: +64 9 415 5535
Fax: +64 9 415 5545

www.doric.co.nz